

**TOPFET dual high side switch**

**PIP3202-DC**

**DESCRIPTION**

Monolithic dual channel high side protected power switch in TOPFET2 technology assembled in a 7 pin plastic surface mount package.

**APPLICATIONS**

General purpose switch for driving lamps, motors, solenoids, heaters.

**QUICK REFERENCE DATA**

SYMBOL	PARAMETER	MIN.	UNIT
$I_L$	Nominal load current (ISO)	8	A
SYMBOL	PARAMETER	MAX.	UNIT
$V_{BG}$	Continuous off-state supply voltage	50	V
$I_L$	Continuous load current	16	A
$T_j$	Continuous junction temperature	150	°C
$R_{ON}$	On-state resistance, $T_j = 25^\circ\text{C}$	40	mΩ

**FEATURES**

- Vertical power TrenchMOS
- Low on-state resistance
- CMOS logic compatible
- Very low quiescent current
- Overtemperature protection
- Load current limiting
- Latched overload and short circuit protection
- Overvoltage and undervoltage shutdown with hysteresis
- Off-state open circuit load detection
- Diagnostic status indication
- Voltage clamping for turn off of inductive loads
- ESD protection on all pins
- Reverse battery, overvoltage and transient protection

**FUNCTIONAL BLOCK DIAGRAM**

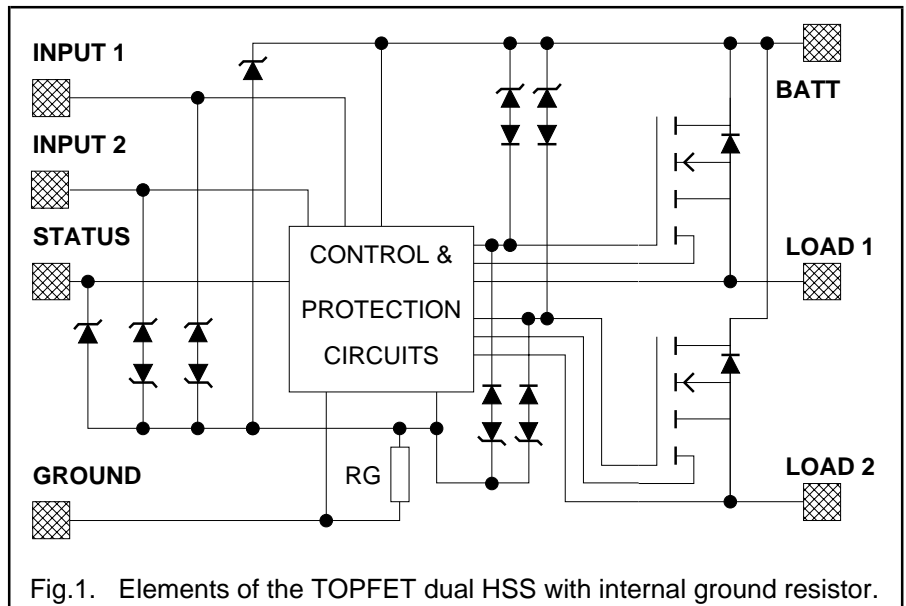

**PINNING - SOT427**

PIN	DESCRIPTION
1	load 1
2	ground
3	input 1
4	connected to mb
5	status
6	input 2
7	load 2
mb	battery

**PIN CONFIGURATION**

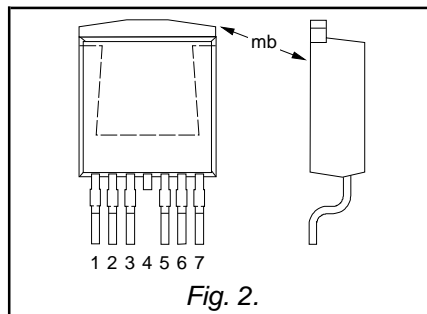

**SYMBOL**

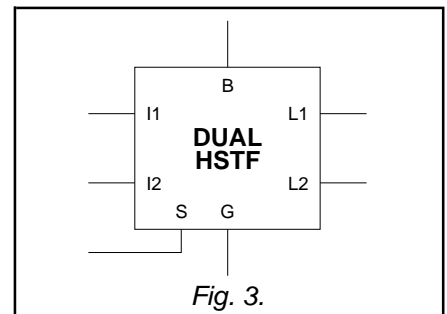

**CONVENTION**

Positive currents flow into pins, except for load and ground pins.

## TOPFET dual high side switch

PIP3202-DC

**LIMITING VALUES**

Limiting values in accordance with the Absolute Maximum System (IEC 134)

SYMBOL	PARAMETER	CONDITIONS	MIN.	MAX.	UNIT
$V_{BG}$	Continuous supply voltage		0	50	V
$I_L$	Continuous load current per channel	$T_{mb} \leq 135^\circ\text{C}$	-	8	A
$P_D$	Total power dissipation	$T_{mb} \leq 25^\circ\text{C}$	-	83.3	W
$T_{stg}$	Storage temperature		-55	175	$^\circ\text{C}$
$T_j$	Continuous junction temperature <sup>1</sup>		-40	150	$^\circ\text{C}$
	<b>Reverse battery voltages<sup>2</sup></b>				
$V_{GB}$	Continuous reverse voltage		-	16	V
$V_{GB}$	Peak reverse voltage		-	32	V
	<b>Application information</b>				
$R_i, R_s$	External resistors <sup>3</sup>	to limit input, status currents	3.2	-	$\text{k}\Omega$
	<b>Input and status currents</b>				
$I_i$	Continuous input current		-5	5	mA
$I_s$	Continuous status current		-5	5	mA
$I_i$	Repetitive peak input current	$\delta \leq 0.1, t_p = 300 \mu\text{s}$	-50	50	mA
$I_s$	Repetitive peak status current	$\delta \leq 0.1, t_p = 300 \mu\text{s}$	-50	50	mA
	<b>Inductive load clamping</b>				
$E_{BL}$	Non-repetitive clamping energy (one channel)	$V_{BG} = 13 \text{ V}, I_L = 8 \text{ A}$ $T_j = 150^\circ\text{C}$ prior to turn-off	-	150	mJ

**ESD LIMITING VALUE**

SYMBOL	PARAMETER	CONDITIONS	MIN.	MAX.	UNIT
$V_C$	Electrostatic discharge capacitor voltage	Human body model; $C = 250 \text{ pF}; R = 1.5 \text{ k}\Omega$	-	2	kV

1 For normal continuous operation. A higher  $T_j$  is allowed as an overload condition but at the threshold  $T_{j(TO)}$  the over temperature trip operates to protect the switch.

2 Reverse battery voltage is allowed only with external resistors to ensure that the input and status currents do not exceed the limiting values. The internal ground resistor limits the reverse battery ground current. The connected loads must limit the reverse load currents. Power is dissipated and the  $T_j$  rating must be observed.

3 To limit currents during reverse battery and transient overvoltages (positive or negative).

## TOFET dual high side switch

PIP3202-DC

## THERMAL CHARACTERISTIC

SYMBOL	PARAMETER	CONDITIONS	MIN.	TYP.	MAX.	UNIT
$R_{th\ j-mb}$	<b>Thermal resistance<sup>1</sup></b>					
	Junction to mounting base	per channel both channels	- -	2.4 1.2	3 1.5	K/W K/W

## STATIC CHARACTERISTICS

Limits are at  $-40^{\circ}\text{C} \leq T_{mb} \leq 150^{\circ}\text{C}$  and typicals at  $T_{mb} = 25^{\circ}\text{C}$  unless otherwise stated

SYMBOL	PARAMETER	CONDITIONS	MIN.	TYP.	MAX.	UNIT				
$V_{BG}$ $V_{BL}$ $V_{GL}$	<b>Clamping voltages</b>									
	Battery to ground	$I_G = 1\text{ mA}$	45	55	65	V				
	Battery to load per channel	$I_L = I_G = 1\text{ mA}$	50	55	65	V				
$V_{GL}$	Ground to load <sup>2</sup>	$I_L = 10\text{ mA}$	18	23	28	V				
		$I_L = 10\text{ A}; t_p = 300\ \mu\text{s}$	20	25	30	V				
$V_{BG}$	<b>Supply voltage</b> Operating range <sup>3</sup>	battery to ground -	5.5	-	35	V				
$I_B$	<b>Currents</b> Total quiescent current <sup>4</sup>	$9\text{ V} \leq V_{BG} \leq 35\text{ V}$ $V_{LG} = 0\text{ V}$ $T_{mb} = 25^{\circ}\text{C}$	-	-	20	$\mu\text{A}$				
		$T_{mb} = 25^{\circ}\text{C}$	-	0.1	1	$\mu\text{A}$				
$I_L$	Off-state load current per channel	$V_{BL} = V_{BG}$ $T_{mb} = 25^{\circ}\text{C}$	-	-	10	$\mu\text{A}$				
$I_G$	Operating current	one channel on	-	1.8	3	mA				
		both channels on	-	3.6	6	mA				
$I_L$	Nominal load current <sup>5</sup>	$V_{BL} = 0.5\text{ V}; T_{mb} = 85^{\circ}\text{C}$	8	-	-	A				
$R_G$	Effective internal ground resistance <sup>6</sup>	$I_G = -200\text{ mA}; t_p = 300\ \mu\text{s}$	40	75	100	$\Omega$				
$R_{ON}$ $R_{ON}$	<b>Resistances per channel</b> On-state resistance	$V_{BG}$	$I_L$	$t_p^7$	$T_j$					
		9 to 35 V								10 A
						150 $^{\circ}\text{C}$	-	60	80	m $\Omega$
	5.5 V	5 A	300 $\mu\text{s}$	25 $^{\circ}\text{C}$	-	50	60	m $\Omega$		
					150 $^{\circ}\text{C}$	-	100	120	m $\Omega$	

1 Of the output Power MOS transistors.

2 For a high side switch, the load pin voltage goes negative with respect to ground during the turn-off of an inductive load. This negative voltage is clamped by the device.

3 On-state resistance is increased if the supply voltage is less than 7 V.

4 This is the continuous current drawn from the battery when both inputs are low and includes leakage currents to the loads.

5 Per channel but with both channels conducting. Defined as in ISO 10483-1.

6 Equivalent of the parallel connected resistors for both channels.

7 The supply and input voltage for the  $R_{ON}$  tests are continuous. The specified pulse duration  $t_p$  refers only to the applied load current.

## TOFET dual high side switch

PIP3202-DC

**INPUT CHARACTERISTICS**

$5.5 \text{ V} \leq V_{\text{BG}} \leq 35 \text{ V}$ . Limits are at  $-40^\circ\text{C} \leq T_{\text{mb}} \leq 150^\circ\text{C}$  and typicals at  $T_{\text{mb}} = 25^\circ\text{C}$  unless otherwise stated.

SYMBOL	PARAMETER	CONDITIONS	MIN.	TYP.	MAX.	UNIT
$I_{\text{I}}$	Input current	$V_{\text{IG}} = 5 \text{ V}$	20	60	160	$\mu\text{A}$
$V_{\text{IG}}$	Input clamping voltage	$I_{\text{I}} = 200 \mu\text{A}$	5.5	7	8.5	V
$V_{\text{IG(ON)}}$	Input turn-on threshold voltage		-	2.1	3	V
$V_{\text{IG(OFF)}}$	Input turn-off threshold voltage		1.2	1.8	-	V
$\Delta V_{\text{IG}}$	Input turn-on hysteresis		0.15	0.3	0.5	V
$I_{\text{I(ON)}}$	Input turn-on current	$V_{\text{IG}} = 3 \text{ V}$	-	-	100	$\mu\text{A}$
$I_{\text{I(OFF)}}$	Input turn-off current	$V_{\text{IG}} = 1.2 \text{ V}$	12	-	-	$\mu\text{A}$

**OPEN CIRCUIT DETECTION CHARACTERISTICS**

An open circuit load on either channel can be detected in the off-state. Refer to TRUTH TABLE. This feature requires external load pull-up to a positive supply voltage via a suitable resistor. Limits are at  $-40^\circ\text{C} \leq T_{\text{mb}} \leq 150^\circ\text{C}$  and typical is at  $T_{\text{mb}} = 25^\circ\text{C}$ .

SYMBOL	PARAMETER	CONDITIONS	MIN.	TYP.	MAX.	UNIT
	<b>Open circuit detection</b>					
$V_{\text{LG(OC)}}$	Load ground threshold voltage	$V_{\text{BG}} \geq 9 \text{ V}$	1.5	2.5	3.5	V
$I_{\text{B(OC)}}$	Supply quiescent current per OC channel	$V_{\text{BG}} = V_{\text{LG}} = 16 \text{ V}$ open circuit detected, other channel off	-	0.8	1.5	mA
$-I_{\text{L(OC)}}$	Load ground current per channel	$V_{\text{LG}} = 16 \text{ V}$ $V_{\text{LG}} = 3.5 \text{ V}$	-	200	300	$\mu\text{A}$
$t_{\text{d(OC)}}$	Status delay time	input low to status low	-	65	100	$\mu\text{s}$
	<b>Application information</b>					
$R_{\text{ext}}$	External load pull-up resistance per channel	$V_{\text{ext}} = 5 \text{ V}$	-	10	-	k $\Omega$

## TOFET dual high side switch

PIP3202-DC

**UNDERVOLTAGE & OVERVOLTAGE CHARACTERISTICS**Limits are at  $-40^{\circ}\text{C} \leq T_{\text{mb}} \leq 150^{\circ}\text{C}$  and typicals at  $T_{\text{mb}} = 25^{\circ}\text{C}$ . Refer to TRUTH TABLE.

SYMBOL	PARAMETER	CONDITIONS	MIN.	TYP.	MAX.	UNIT
<b>Undervoltage</b>						
$V_{\text{BG(UV)}}$	Low supply threshold voltage <sup>1</sup>		2	4.2	5.3	V
$\Delta V_{\text{BG(UV)}}$	Hysteresis		0.1	0.5	1	V
<b>Overvoltage</b>						
$V_{\text{BG(OV)}}$	High supply threshold voltage <sup>2</sup>		35	40	45	V
$\Delta V_{\text{BG(OV)}}$	Hysteresis		0.4	1	2	V
$I_{\text{BG(OV)}}$	Operating current per channel	$V_{\text{BG}} > V_{\text{BG(OV)}}$	-	1	2	mA

**OVERLOAD PROTECTION CHARACTERISTICS**

Independent protection per channel. Refer to TRUTH TABLE.

 $5.5 \text{ V} \leq V_{\text{BG}} \leq 35 \text{ V}$ , limits are at  $-40^{\circ}\text{C} \leq T_{\text{mb}} \leq 150^{\circ}\text{C}$  and typicals at  $T_{\text{mb}} = 25^{\circ}\text{C}$  unless otherwise stated.

SYMBOL	PARAMETER	CONDITIONS	MIN.	TYP.	MAX.	UNIT
<b>Overload protection</b>						
$I_{\text{L(lim)}}$	Load current limiting	$V_{\text{BL}} = V_{\text{BG}}$ ; $t_{\text{p}} = 300 \mu\text{s}$				
		$V_{\text{BG}} \geq 8 \text{ V}$ $V_{\text{BG}} = 5.5 \text{ V}$	18 15	30 27	42 42	A A
<b>Short circuit load protection</b>						
$P_{\text{D(TO)}}$	Overload power threshold	$T_{\text{mb}} \leq 125^{\circ}\text{C}$ prior to overload <sup>3</sup> for latched protection <sup>4</sup>	100	150	200	W
$T_{\text{DSC}}$	Characteristic time	which determines trip time <sup>5</sup>	-	200	500	$\mu\text{s}$
<b>Overtemperature protection</b>						
$T_{\text{j(TO)}}$	Threshold junction temperature		150	170	190	$^{\circ}\text{C}$
$\Delta T_{\text{j(TO)}}$	Hysteresis <sup>6</sup>		3	10	20	$^{\circ}\text{C}$

1 Undervoltage sensors causes each channel to switch off and reset.

2 Overvoltage sensors causes each output channel to switch off to protect its load.

3 Above this temperature measurement of these parameters is prevented because OT protection may occur prior to SC protection.

4 SC protection for  $P_{\text{D}} > P_{\text{D(TO)}}$  is latched. Normal operation may only be resumed after the input is toggled low then high again. Normal operation is maintained as long as  $P_{\text{D}} < P_{\text{D(TO)}}$  and  $T_{\text{j}} < T_{\text{j(TO)}}$ .5 Trip time  $t_{\text{d sc}}$  varies with overload dissipation  $P_{\text{D}}$  according to the *exponential model* formula  $t_{\text{d sc}} \approx T_{\text{DSC}} / \text{LN}[ P_{\text{D}} / P_{\text{D(TO)}} ]$ .

6 After cooling below the reset temperature the channel will resume normal operation.

## TOPFET dual high side switch

PIP3202-DC

**STATUS CHARACTERISTICS**

The status output is an open drain transistor, and requires an external pull-up circuit to indicate a logic high. Limits are at  $-40^{\circ}\text{C} \leq T_{\text{mb}} \leq 150^{\circ}\text{C}$  and typicals at  $T_{\text{mb}} = 25^{\circ}\text{C}$  unless otherwise stated. Refer to TRUTH TABLE.

SYMBOL	PARAMETER	CONDITIONS	MIN.	TYP.	MAX.	UNIT
$V_{\text{SG}}$	Status clamping voltage	$I_{\text{S}} = 100 \mu\text{A}$	5.5	7	8.5	V
$V_{\text{SG(LO)}}$	Status low voltage	$I_{\text{S}} = 100 \mu\text{A}$	-	0.7	0.9	V
$I_{\text{S}}$	Status leakage current	$I_{\text{S}} = 250 \mu\text{A}$	-	-	1.1	V
		$V_{\text{SG}} = 5 \text{ V}$	-	-	10	$\mu\text{A}$
		$T_{\text{mb}} = 25^{\circ}\text{C}$	-	0.1	1	$\mu\text{A}$
$I_{\text{S(SAT)}}$	Status saturation current <sup>1</sup>	$V_{\text{SG}} = 5 \text{ V}$	5	10	15	mA
	<b>Application information</b>					
$R_{\text{S}}$	External pull-up resistor		-	47	-	k $\Omega$

**TRUTH TABLE**

INPUT		ABNORMAL CONDITIONS DETECTED									LOAD OUTPUT		STATUS	DESCRIPTION
		SUPPLY		LOAD 1			LOAD 2							
1	2	UV	OV	OC	SC	OT	OC	SC	OT	1	2			
L	L	0	X	0	X	X	0	X	X	OFF	OFF	H	both off & normal	
L	L	0	X	1	X	X	X	X	X	OFF	OFF	L	both off, one/both OC or short to V+	
L	H	0	X	1	X	X	0	0	0	OFF	ON	L	one off & OC, other on & normal	
H	L	0	0	0	0	0	0	0	0	ON	OFF	H	one on & normal, other off & normal	
H	H	0	0	0	0	0	0	0	0	ON	ON	H	both on & normal	
H	X	1	0	X	X	X	0	X	X	OFF	OFF	H	supply undervoltage lockout	
H	X	0	1	X	0	0	X	0	0	OFF	OFF	H	supply overvoltage shutdown	
H	X	0	0	0	1	X	X	X	X	OFF	X	L	one SC tripped	
H	L	0	0	0	1	X	0	0	X	OFF	OFF	L	one SC tripped, other off & normal	
H	H	0	0	0	1	X	0	0	0	OFF	ON	L	one SC tripped, other on & normal	
H	X	0	0	0	0	1	X	X	X	OFF	X	L	one OT shutdown	
H	L	0	0	0	0	1	0	0	X	OFF	OFF	L	one OT shutdown, other off & normal	
H	H	0	0	0	0	1	0	0	0	OFF	ON	L	one OT shutdown, other on & normal	

**KEY TO ABBREVIATIONS**

L	logic low	UV	undervoltage
H	logic high	OV	overvoltage
X	don't care	OC	open circuit
0	condition not present	SC	short circuit
1	condition present	OT	overtemperature

<sup>1</sup> For example with the pull-up resistor short circuited while the status transistor is conducting. This condition should be avoided in order to prevent possible interference with normal operation of the device.

## TOFET dual high side switch

PIP3202-DC

**SWITCHING CHARACTERISTICS** $T_{mb} = 25\text{ }^{\circ}\text{C}$ ,  $V_{BG} = 13\text{ V}$ , for resistive load  $R_L = 13\text{ }\Omega$  per channel.

SYMBOL	PARAMETER	CONDITIONS	MIN.	TYP.	MAX.	UNIT
$t_{d\ on}$	<b>During turn-on</b>	from input going high				
	Delay time	to 10% $V_L$	-	30	-	$\mu\text{s}$
	$dV/dt_{on}$	Rate of rise of load voltage	0.5	1	2	$\text{V}/\mu\text{s}$
$t_{on}$	Total switching time	to 90% $V_L$	-	100	400	$\mu\text{s}$
$t_{d\ off}$	<b>During turn-off</b>	from input going low				
	Delay time	to 90% $V_L$	-	20	-	$\mu\text{s}$
	$dV/dt_{off}$	Rate of fall of load voltage	0.5	1	2	$\text{V}/\mu\text{s}$
$t_{off}$	Total switching time	to 10% $V_L$	-	40	200	$\mu\text{s}$

**CAPACITANCES** $T_{mb} = 25\text{ }^{\circ}\text{C}$ ;  $f = 1\text{ MHz}$ ;  $V_{IG} = 0\text{ V}$ 

SYMBOL	PARAMETER	CONDITIONS	MIN.	TYP.	MAX.	UNIT
$C_{sg}$	Status capacitance	$V_{SG} = 5\text{ V}$	-	11	15	$\text{pF}$
	<b>per channel</b>					
$C_{ig}$	Input capacitance	$V_{BG} = 13\text{ V}$	-	15	20	$\text{pF}$
$C_{bl}$	Output capacitance	$V_{BL} = 13\text{ V}$	-	265	375	$\text{pF}$

TOPFET dual high side switch

PIP3202-DC

MECHANICAL DATA

Plastic single-ended surface mounted package (Philips version of D<sup>2</sup>-PAK);  
7 leads (one lead cropped)

SOT427

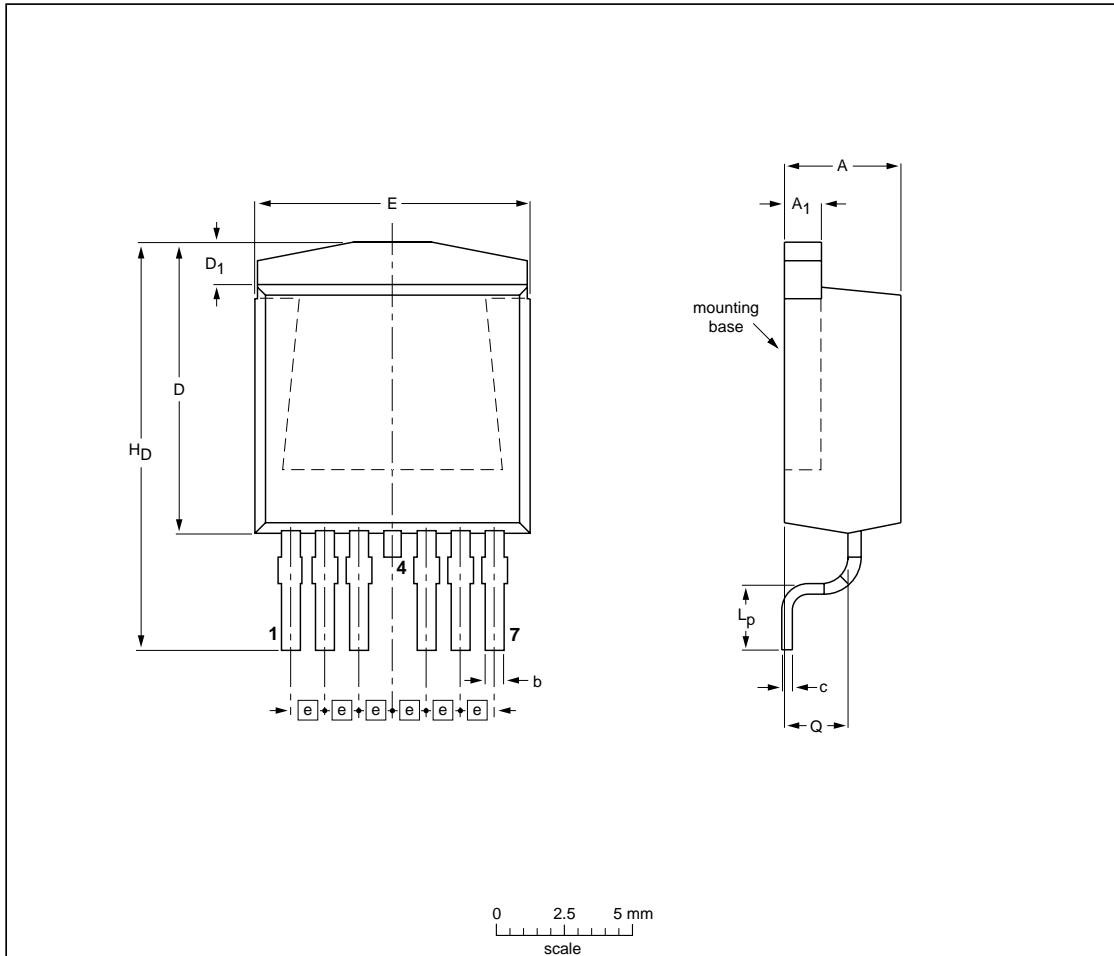

DIMENSIONS (mm are the original dimensions)

UNIT	A	A <sub>1</sub>	b	c	D max.	D <sub>1</sub>	E	e	L <sub>p</sub>	H <sub>D</sub>	Q
mm	4.50 4.10	1.40 1.27	0.85 0.60	0.64 0.46	11	1.60 1.20	10.30 9.70	1.27	2.90 2.10	15.80 14.80	2.60 2.20

OUTLINE VERSION	REFERENCES				EUROPEAN PROJECTION	ISSUE DATE
	IEC	JEDEC	EIAJ			
SOT427						99-06-25 01-04-18

Fig.4. SOT427 surface mounting package<sup>1</sup>, centre pin connected to mounting base.

<sup>1</sup> Epoxy meets UL94 V0 at 1/8". Net mass: 1.5 g.

For soldering guidelines and SMD footprint design, please refer to Data Handbook SC18.



## TOFET dual high side switch

PIP3202-DC

**DEFINITIONS**

<b>DATA SHEET STATUS</b>		
<b>DATA SHEET STATUS<sup>1</sup></b>	<b>PRODUCT STATUS<sup>2</sup></b>	<b>DEFINITIONS</b>
Objective data	Development	This data sheet contains data from the objective specification for product development. Philips Semiconductors reserves the right to change the specification in any manner without notice
Preliminary data	Qualification	This data sheet contains data from the preliminary specification. Supplementary data will be published at a later date. Philips Semiconductors reserves the right to change the specification without notice, in order to improve the design and supply the best possible product
Product data	Production	This data sheet contains data from the product specification. Philips Semiconductors reserves the right to make changes at any time in order to improve the design, manufacturing and supply. Changes will be communicated according to the Customer Product/Process Change Notification (CPCN) procedure SNW-SQ-650A
<b>Limiting values</b>		
Limiting values are given in accordance with the Absolute Maximum Rating System (IEC 134). Stress above one or more of the limiting values may cause permanent damage to the device. These are stress ratings only and operation of the device at these or at any other conditions above those given in the Characteristics sections of this specification is not implied. Exposure to limiting values for extended periods may affect device reliability.		
<b>Application information</b>		
Where application information is given, it is advisory and does not form part of the specification.		
© Philips Electronics N.V. 2001		
All rights are reserved. Reproduction in whole or in part is prohibited without the prior written consent of the copyright owner.		
The information presented in this document does not form part of any quotation or contract, it is believed to be accurate and reliable and may be changed without notice. No liability will be accepted by the publisher for any consequence of its use. Publication thereof does not convey nor imply any license under patent or other industrial or intellectual property rights.		

**LIFE SUPPORT APPLICATIONS**

These products are not designed for use in life support appliances, devices or systems where malfunction of these products can be reasonably expected to result in personal injury. Philips customers using or selling these products for use in such applications do so at their own risk and agree to fully indemnify Philips for any damages resulting from such improper use or sale.

<sup>1</sup> Please consult the most recently issued datasheet before initiating or completing a design.

<sup>2</sup> The product status of the device(s) described in this datasheet may have changed since this datasheet was published. The latest information is available on the Internet at URL <http://www.semiconductors.philips.com>.